

operation manual SOLDOS

security devices

- 1. Before the installation of a SOLDOS all materials in the room have to be checked on their corrosion resistance against the saline mixture of water and air both in the adequate steam cabinet and additional and discharged air shafts.**

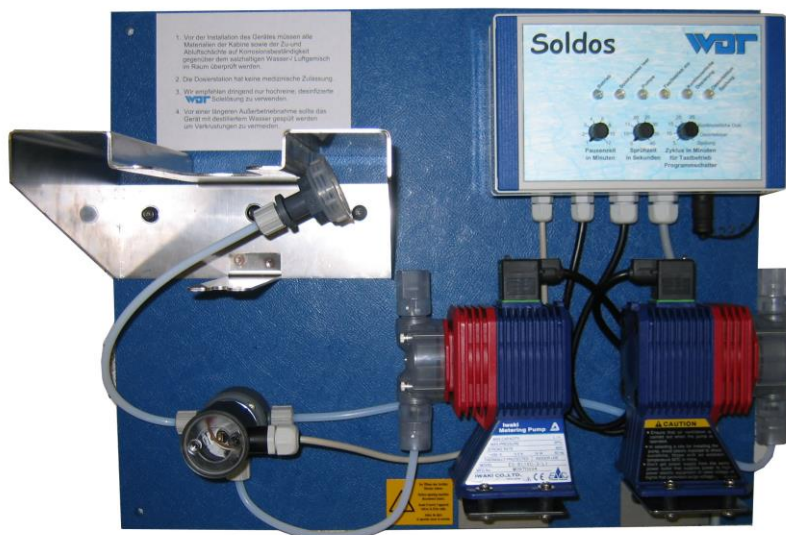

- 2. The SOLDOS is not licensed for medical purpose.**

- 3. Use only pure, disinfected **WDT** brine solution with a salt concentration of app. 5%. WDT brine solution is delivered in a sterile condition in a closed container. Outstanding brine solution is affected by bacterial impact and so should not be used.**

- 4. Consider disinfection instructions and durability of the brine solution! (see point 4.3)**

Operation manual

	page
1. Function	3
2. Technical Data	3
3. Installation	4
4. Taking the unit into operation	7
4.1 Attaching the brine reservoir to the unit	7
4.2 Operation types	8
4.3 Disinfection	8
4.4 Durability of the brine solution	9
5. Maintenance	8
6. Wiring diagramme	8
7. Spare parts list	10

Dosing station for the fine spraying of brine solution for steam cabinets and brine bathes to create a salty sea climate

1. Function

The SOLDOS sprays brine solution into steam- and brine rooms. After a certain time a salty sea climate comes up in the room. The SOLDOS is useable in rooms for up to app. 25 m² floor space.

The brine solution is pressed through a fine nozzle by a high pressure solenoid diaphragm pump and nebulized. The pump does not have to be deaerated as the brine solution reservoir is mounted on a higher level than the pump. If the reservoir will get empty the nebulisation stops and the green LED blinks. This fault indication can be converted for a remote indication. For the empty report a pressure switch is mounted below the reservoir. The unit can be operated in an continous interval operation or by push-button operation.

2. Technical Data

The dosing unit SOLDOS consists of:

- 1 solenoid diaphragm pump
- console stainless steel for 5l or 1l brine reservoir (option)
- spraying nozzle (stainless steel) with cover screen and grommet
- empty switch for the switch-off if reservoir is empty
- control housing H120 x W200 x D90mm incl. microprocessor controller
- mounting plate PP blue H400 x B500 x10mm
- installation depth 250mm
- dosing performance: 1,6 l/h (in endurance run) at 5bar
- power consumption: 10 Watt
- power supply: plug 230V / 50Hz

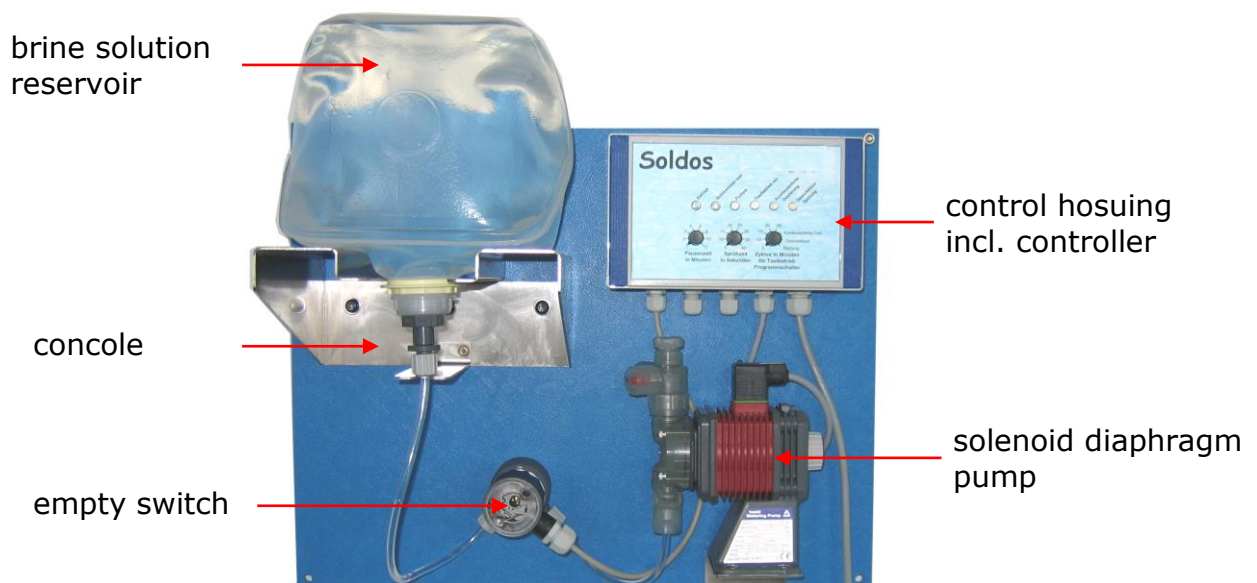

3. Installation

Before the installation of a SOLDOS all materials in the steam cabinet have to be checked on their corrosion resistance to brine solution!!!

If the SOLDOS is used in wooden cabinets the resistance of the wood has to be checked. Additionally the wood has to be cleaned regularly (Cedarwood can be cleaned easily)!

Attention!!! – please use only pure, disinfected WDT brine with a salt concentration of app. 5%.

The SOLDOS has to be installed on a capable place next to the accordant cabinet, but not directly on the back board of the wall as a disturbing noise due to vibration might come up. Electrical supply by power socket 230V/AC.

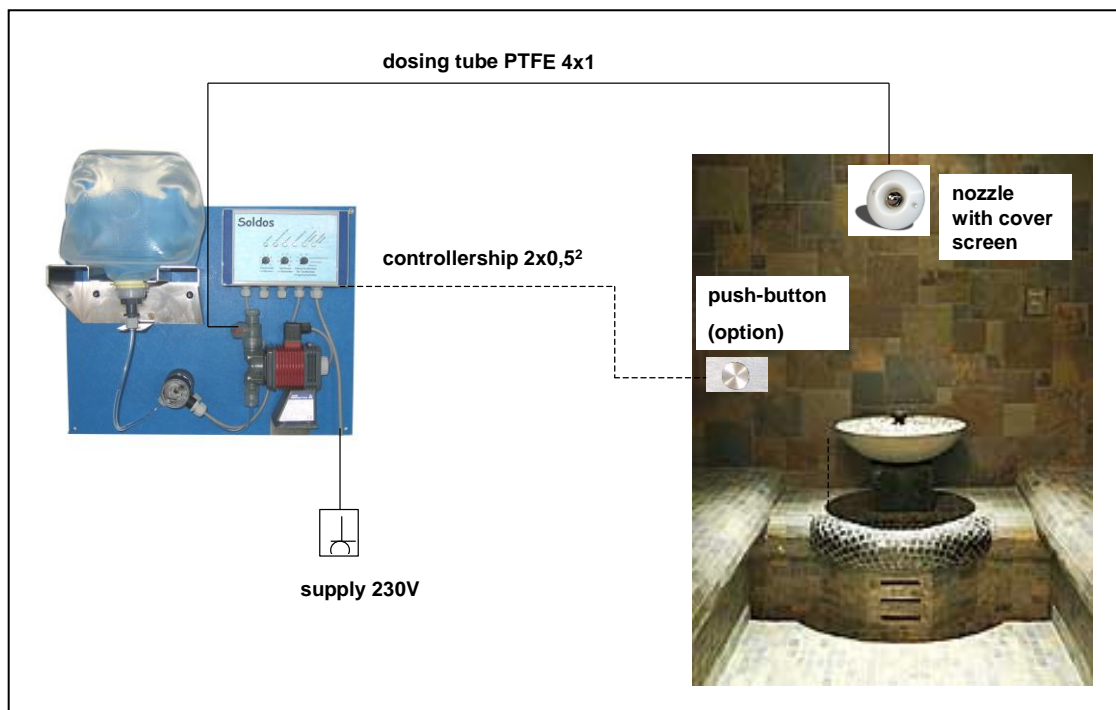

In order to prevent a drainage of the politainer, **the nozzle has to be installed at a higher level than the SOLDOS with the politainer!!** If this is not possible a spring loaded non-return valve has to be installed.

Attention! Do not crack the pressure tubing at the relocation to the cabinet!!!.

Grommet – cover screen for the nozzle:

For the installation of the nozzle and the cover screen a boring through the wall of the cabinet has to be made (diameter 40mm). The grommet is glued into the boring diffusion resistant.

nozzle and cover screen

grommet

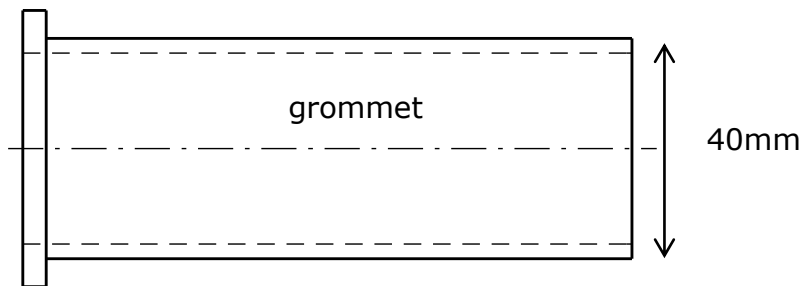

Cover screen and nozzle with hose connection are delivered screwed together:

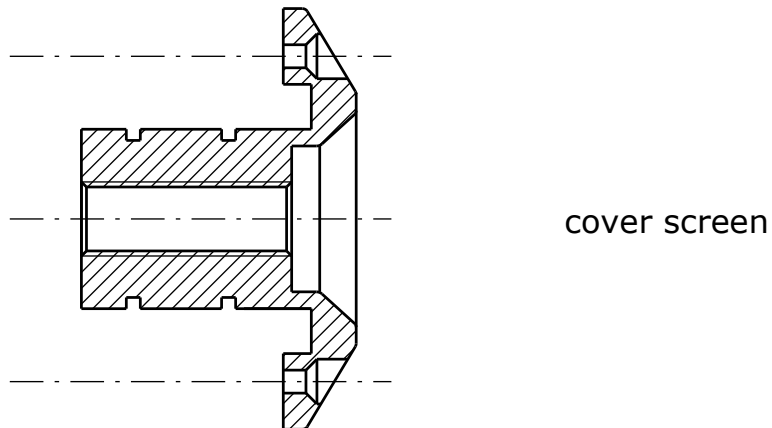

The dosing tube PTFE 4x1 is lead through the grommet from direction of the SOLDOS and connected to the nozzle. Now the cover screen incl. Nozzle is shoved into the grommet and fixed at the wall with the enclosed screws. Furthermore we recommend to lead the dosing tube in a protection tube. Pay attention that the tube stays flexible at the backside.

Connection of the dosing tube at the pump

For the connection of the dosing tube to the diaphragm pump the cap nut (1) has to be unscrewed from the connection nipple (2) at first. The cap nut is now shoved over the hose and fixed.

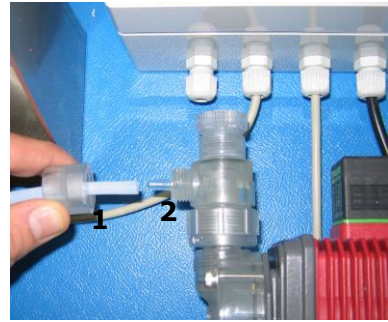

Attention! Do not crack the pressure tubing at the relocation to the cabinet! If this happens a new tubing has to be installed.

4. Taking the unit into operation

4.1 Attaching the brine reservoir to the unit

Before taking the unit into operation the brine solution reservoir has to be attached to the unit. At the programme switch the dosing performance is adjusted by the pause- and spraying time. The programme switch is to set up the type of operation, the test programmes and the cycle time for the push-button operation.

When you take the unit into operation we recommend to set the pause- and spraying time on a middle position (pause time 4 minutes/ spraying time 25 seconds). Starting from this values the times have to be adapted according to the basic conditions at the point of use (measures of the room, steam quantity). The unit has to be switched-on with the main switch on the right sight of the controller before it can be taken into operation.

Attaching the brine reservoir:

1. Screw-off the original lid of the brine reservoir.
2. Pull out the special lid from the nipple of the suction tube of the SOLDOS.
3. Screw the special lid onto the brine reservoir.
4. Push the suction tube with nipple into the special lid.
5. Pull the connected reservoir into the console. Pay attention that the flange ring sits correctly in the guiding.

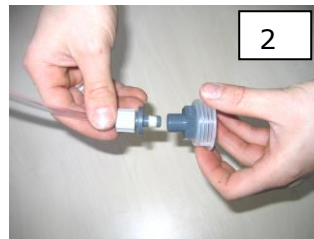

4.2 Operation types

Interval operation - „continuous dosing“

At the continuous dosing the programme starts after the unit has been switched-on. The spraying time is adjustable by a rotary knob on 5-10-15-20-25-30-35 or 40 seconds. The pause time between the single sprays is adjustable on 1-2-3-4-6-8-10 or 12 minutes. This cycle is repeated until the unit is switched-off.

Put the programme switch on „continuous dosing“. The LED „continuous dosing“ shines. Adjust now the spraying- and the pause time.

Example: pause time 4 minutes, spraying time 20 seconds
The unit sprays brine solution every 4 minutes for 20 seconds.

Push-button operation

The push-button has to be connected according to the wiring diagram. The demanded cycle time is adjusted at the programme switch. The LED „push-button operation“ shines.

After pressing the connected push-button the same procedure as described above („continuous dosing“) starts. After the lapse of the adjusted cycle time on 5 – 10 – 15 – 20 or 25 minutes the dosing stops and the SOLDOS is ready for a restart.

4.3 Disinfection

Ensure before every disinfection that the steam room is out of operation and that no guests will be inside!!

The disinfection of the unit has to be accomplished at every exchange of the canister or at least once per month!

The programme of the SOLDOS includes a disinfection function to prevent bacterial impact. Therefore the reservoir the empty brine reservoir has to be flushed and the filled with app. 250ml of fresh water. Put 1 disinfectant tablette into the reservoir, dissolve it, attach the reservoir to the SOLDOS and put the programme switch on „**disinfection**“.

Now the pump doses disinfectant for 4 minutes into the system. Afterwards the unit is locked for 11 minutes (pause time/ reaction time).

After this pause time a brine solution reservoir has to be attached to the unit again. Put the programme switch on „**flushing**“. Now the system is flushed for 4 minutes with brine solution to bring the disinfectant completely out of the system. After this the unit is ready for operation again.

Afterwards we recommend to clean the steam room. During the disinfection / flushing the accordant LED shines. If a fault occurs during

one of these programme steps (e.g. reservoir empty), the LED „disinfection/ flushing“ blinks and the procedure has to be repeated.

4.4 Durability of the brine solution

Every politainer is labelled with the maximum expiry date. Furthermore, every politainer has to be used up within 4 weeks after opening.

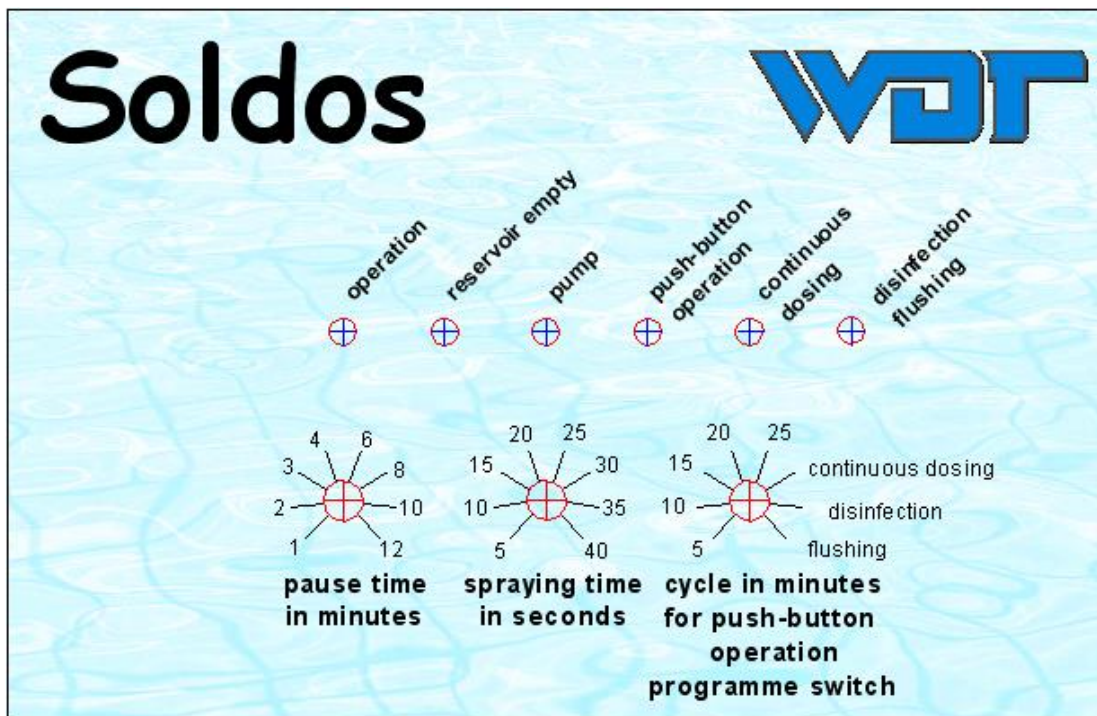

5. Maintenance

The single components require different maintenance efforts:

Solenoid diaphragm pump:

Change diaphragm annually

Taking the unit out of operation: we recommend to flush the whole system with distilled water, to prevent incrustations.

Maintenance of the rooms

The interior of steam rooms is normally flushed with water at the end of a day, so no deposits or incrustations will come up.

In dry rooms deposits can come up very fast. We recommend a regular cleaning of these rooms!

Tap water includes lime that would block the very fine boring of the nozzle

6. Wiring diagramme

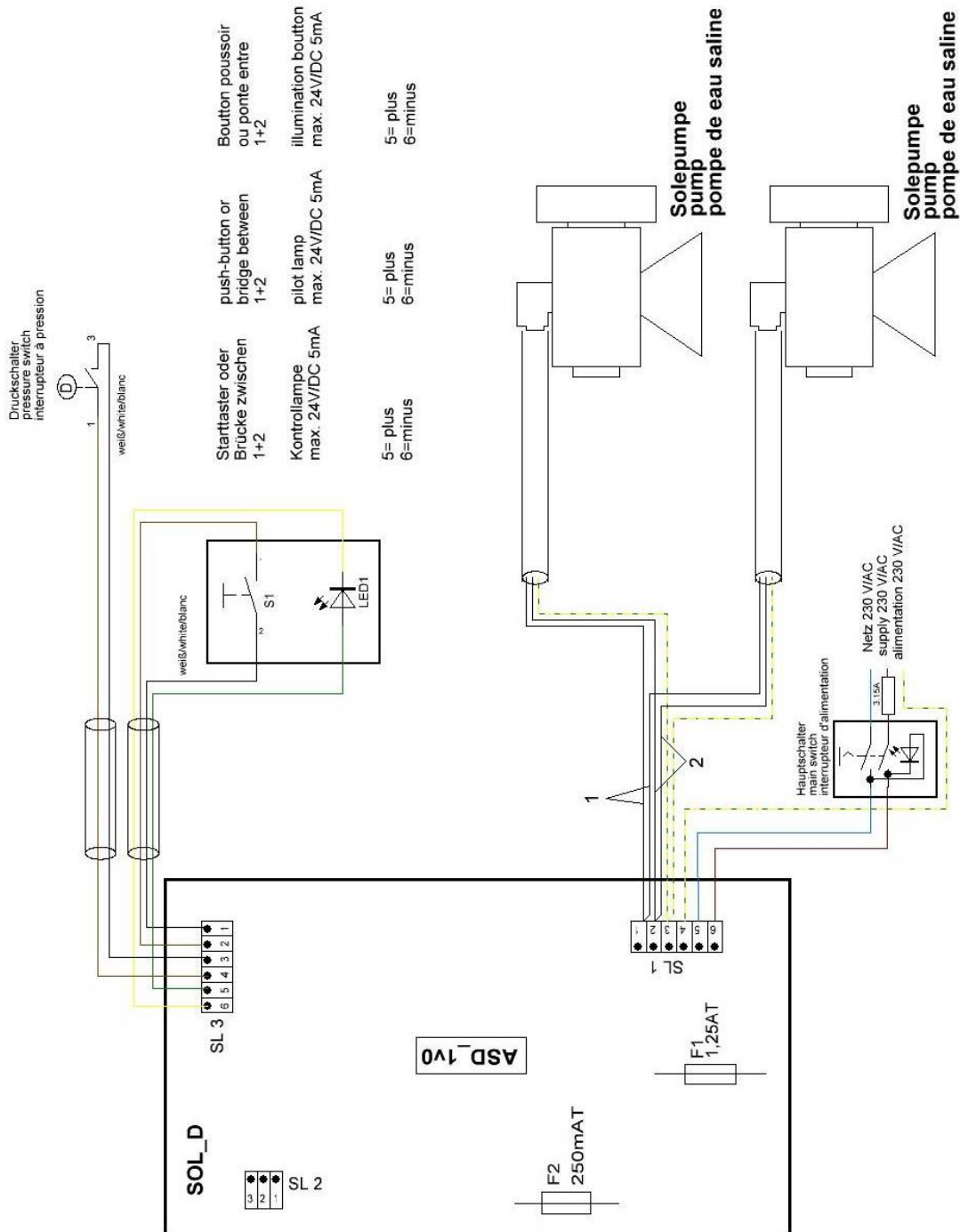

potenzialfreier
Schaltkontakt:
Störmeldung Sole leer
3 = S
2 = P
1 = Ö
non-volt
contact:
fault report brine
solution empty
exempt de potentiel
signalement de défauts

7. Spare parts list

17434	controller for SOLDOS complete with housing
14932	control board for Soldos V3
12764	main switch 2p A-E 10A d20 round
10080	pressure switch SOLDOS
10083	protection cover for pressure switch
17386	adapter d50 - M10x1 for pressure switch
14785	solenoid diaphragm pump EH-B10VC
10726	diaphragm for EH-B10, EX0015, EX-A10
13082	solenoid valve connector with LED
17324	console stainless steel for SOLDOS pump
14421	nozzle for the fine spraying of brine solution with cover screen and 5m PTFE tube 4x1
15831	nozzle for SOLDOS 0.2
15554	cover screen for Soldos nozzle
10432	PTFE tube 4x1
11127	hose PVC transparent 4x1mm
11003	cap nut 6mm PP ¼"
17437	canister coupling for SOLDOS